



PLFY-P-VCM-E



PLFY-P-VBM-E

PLFY-P-VCM-E
PLFY-P-VBM-E

1. SPECIFICATIONS	IU-E- 2
2. EXTERNAL DIMENSIONS	IU-E- 5
3. ELECTRICAL WIRING DIAGRAMS	IU-E- 7
4. SOUND LEVELS	
4-1. Sound levels	IU-E- 9
4-2. NC curves	IU-E- 9
5. TEMPERATURE/AIRFLOW DISTRIBUTIONS	
5-1. Temperature distributions	IU-E- 12
5-2. Airflow distributions	IU-E- 13
6. Optional parts for PLFY-P-VBM-E	IU-E- 14

- A
- B
- C
- D
- E**
- F
- G
- H
- V_a
- V_b
- BC
- CT

Cassette ceiling	P20	P25	P32	P40	P50	P63	P71	P80	P100	P125	P140	P200	P250
	0.8HP	1.0HP	1.3HP	1.6HP	2.0HP	2.5HP	2.8HP	3.2HP	4.0HP	5.0HP	5.6HP	8.0HP	10.0HP
PLFY-P-VCM-E	●	●	●	●									
PLFY-P-VBM-E			●	●	●	●		●	●	●			

1. SPECIFICATIONS

R410A Data G4

Model			PLFY-P20VCM-E	PLFY-P25VCM-E	PLFY-P32VCM-E	PLFY-P40VCM-E				
Power source			1-phase 220-240V 50Hz							
Cooling capacity (Nominal)	*1	kW	2.2	2.8	3.6	4.5				
		kcal / h	1,900	2,400	3,100	3,900				
		Btu / h	7,500	9,600	12,300	15,400				
	*2	kcal / h	2,000	2,500	3,150	4,000				
		Power input	kW	0.05	0.05	0.06	0.06			
Current input		A	0.23	0.23	0.28	0.28				
Heating capacity (Nominal)	*3	kW	2.5	3.2	4.0	5.0				
		kcal / h	2,200	2,800	3,400	4,300				
		Btu / h	8,500	10,900	13,600	17,100				
	Power input	kW	0.05	0.05	0.06	0.06				
		Current input	A	0.23	0.23	0.28	0.28			
External finish			Galvanized steel sheet, with grey heat insulation							
External dimension H x W x D		mm	208 x 570 x 570	208 x 570 x 570	208 x 570 x 570	208 x 570 x 570				
		in.	8-1/4" x 22-1/2" x 22-1/2"	8-1/4" x 22-1/2" x 22-1/2"	8-1/4" x 22-1/2" x 22-1/2"	8-1/4" x 22-1/2" x 22-1/2"				
Net weight		kg (lb)	15.5 (35)	15.5 (35)	17 (38)	17 (38)				
Decoration panel	Model		SLP-2AA	SLP-2AA	SLP-2AA	SLP-2AA				
	External finish		White Munsell(0.7Y 8.59/0.97)							
	Dimension		mm	20 x 650 x 650	20 x 650 x 650	20 x 650 x 650	20 x 650 x 650			
	H x W x D		in.	13/16" x 25-5/8" x 25-5/8"	13/16" x 25-5/8" x 25-5/8"	13/16" x 25-5/8" x 25-5/8"	13/16" x 25-5/8" x 25-5/8"			
	Net Weight		kg (lb)	3 (7)	3 (7)	3 (7)	3 (7)			
	Cord heater		kW	0.015	0.015	0.015	0.015			
Heat exchanger			Cross fin & copper tube							
FAN	Type x Quantity		Turbo fan x 1							
	External static press.		0Pa (0mmH ₂ O)	0Pa (0mmH ₂ O)	0Pa (0mmH ₂ O)	0Pa (0mmH ₂ O)				
	Motor type		Single phase induction motor							
	Motor output		kW	0.011	0.015	0.02	0.02			
	Driving mechanism		Direct-driven by motor							
	Airflow rate		m ³ / min	8-9-10	8-9-10	8-9-11	8-9-11			
L / s			133-150-167	133-150-167	133-150-183	133-150-183				
cfm			283-318-353	283-318-353	283-318-388	283-318-388				
Noise level (Low-Mid-High) (measured in anechoic room)		dB <A>	28-31-35 (230V)	28-31-37 (230V)	29-33-38 (230V)	30-34-39 (230V)				
Insulation material			Polyethylene foam (softlon FR)							
Air filter			PP honeycomb fabric (long life type)							
Protection device			Fuse							
Refrigerant control device			LEV							
Connectable outdoor unit			R410A, R407C, R22 CITY MULTI							
Diameter of refrigerant pipe	Liquid	mm (in.)	ø6.35 (ø1/4") Flare	ø6.35 (ø1/4") Flare	ø6.35 (ø1/4") Flare	ø6.35 (ø1/4") Flare				
	Gas	mm (in.)	ø12.7 (ø1/2") Flare	ø12.7 (ø1/2") Flare	ø12.7 (ø1/2") Flare	ø12.7 (ø1/2") Flare				
Field drain pipe size		mm (in.)	O.D. 32mm (1-1/4")							
Drawing	External		IU-VRG01N654							
	Wiring		IU-VRG79N625							
	Refrigerant circle		-							
Standard attachment	Document		Installation manual, Instruction book							
	Accessory		Drain hose I.D. 32mm (1-1/4") (flexible joint)							
Remark	Optional parts		Decoration panel : SLP-2AA *PLFY-P-VCM-E should use together with SLP-2AA.							
	Installation		Details on foundation work, duct work, insulation work, electrical wiring, power source switch, and other items shall be referred to the Installation Manual.							
Note : <table border="0" style="width:100%; border-collapse: collapse;"> <tr> <td style="width:33%; vertical-align: top;"> *1 Nominal cooling condition Indoor : 27°CDB/19°CWB (81°FDB/66°FWB) Outdoor : 35°CDB (95°FDB) Pipe length : 7.5 m (24-9/16 ft) Level difference : 0 m (0 ft) </td> <td style="width:33%; vertical-align: top;"> *2 Nominal cooling condition 27°CDB/19.5°CWB (81°FDB/67°FWB) 35°CDB (95°FDB) 5 m (16-3/8 ft) 0 m (0 ft) </td> <td style="width:33%; vertical-align: top;"> *3 Nominal heating condition 20°CDB (68°FDB) 7°CDB/6°CWB (45°FDB/43°FWB) 7.5 m (24-9/16 ft) 0 m (0 ft) </td> <td style="width:15%; vertical-align: top;"> Unit converter kcal = kW x 860 Btu/h = kW x 3,412 cfm = m³/min x 35.31 lb = kg / 0.4536 </td> </tr> </table>							*1 Nominal cooling condition Indoor : 27°CDB/19°CWB (81°FDB/66°FWB) Outdoor : 35°CDB (95°FDB) Pipe length : 7.5 m (24-9/16 ft) Level difference : 0 m (0 ft)	*2 Nominal cooling condition 27°CDB/19.5°CWB (81°FDB/67°FWB) 35°CDB (95°FDB) 5 m (16-3/8 ft) 0 m (0 ft)	*3 Nominal heating condition 20°CDB (68°FDB) 7°CDB/6°CWB (45°FDB/43°FWB) 7.5 m (24-9/16 ft) 0 m (0 ft)	Unit converter kcal = kW x 860 Btu/h = kW x 3,412 cfm = m ³ /min x 35.31 lb = kg / 0.4536
*1 Nominal cooling condition Indoor : 27°CDB/19°CWB (81°FDB/66°FWB) Outdoor : 35°CDB (95°FDB) Pipe length : 7.5 m (24-9/16 ft) Level difference : 0 m (0 ft)	*2 Nominal cooling condition 27°CDB/19.5°CWB (81°FDB/67°FWB) 35°CDB (95°FDB) 5 m (16-3/8 ft) 0 m (0 ft)	*3 Nominal heating condition 20°CDB (68°FDB) 7°CDB/6°CWB (45°FDB/43°FWB) 7.5 m (24-9/16 ft) 0 m (0 ft)	Unit converter kcal = kW x 860 Btu/h = kW x 3,412 cfm = m ³ /min x 35.31 lb = kg / 0.4536							
* Nominal conditions *1, *3 are subject to JIS B8615-1. * Due to continuing improvement, above specification may be subject to change without notice.										

Ref.: Spec_PLFY-P-VCM-E

1. SPECIFICATIONS

R410A Data G4

Model			PLFY-P32VBM-E	PLFY-P40VBM-E	PLFY-P50VBM-E	PLFY-P63VBM-E	
Power source			1-phase 220-240V 50Hz, 1-phase 220V 60Hz				
Cooling capacity (Nominal)	* 1	kW	3.6	4.5	5.6	7.1	
	* 1	kcal / h	3,100	3,900	4,800	6,100	
	* 1	Btu / h	12,300	15,400	19,100	24,200	
	* 2	kcal / h	3,150	4,000	5,000	6,300	
		Power input	kW	0.03	0.04	0.04	0.05
		Current input	A	0.22	0.29	0.29	0.36
Heating capacity (Nominal)	* 3	kW	4.0	5.0	6.3	8.0	
	* 3	kcal / h	3,400	4,300	5,400	6,900	
	* 3	Btu / h	13,600	17,100	21,500	27,300	
		Power input	kW	0.02	0.03	0.03	0.04
			Current input	A	0.14	0.22	0.29
External finish			Galvanized steel sheet				
External dimension H x W x D		mm	258 x 840 x 840				
		in.	10-3/16" x 33-1/8" x 33-1/8"				
Net weight		kg (lb)	22 (49)	22 (49)	22 (49)	23 (51)	
Decoration panel	Model		PLP-6BA	PLP-6BA	PLP-6BA	PLP-6BA	
	External finish		MUNSELL (6.4Y 8.9/0.4)				
	Dimension		35 x 950 x 950				
	H x W x D		1-3/8" x 37-7/16" x 37-7/16"				
	Net weight		6 (13)				
Heat exchanger			Cross fin (Aluminum fin and copper tube)				
FAN	Type x Quantity		Turbo fan x 1	Turbo fan x 1	Turbo fan x 1	Turbo fan x 1	
	External static press.	Pa	0	0	0	0	
		mmH ₂ O	0	0	0	0	
	Motor type		DC motor				
	Motor output		kW				
	Driving mechanism		Direct-drive				
	Airflow rate (Low-Mid2- Mid1-High)	m ³ / min		11 - 12 - 13 - 14	12 - 13 - 14 - 16	12 - 13 - 14 - 16	14 - 15 - 16 - 18
L / s		183 - 200 - 217 - 233	200 - 217 - 233 - 267	200 - 217 - 233 - 267	233 - 250 - 267 - 300		
cfm		388 - 424 - 459 - 494	424 - 459 - 494 - 565	424 - 459 - 494 - 565	494 - 530 - 565 - 636		
Noise level (Low-Mid2-Mid1-High) (measured in anechoic room)		dB <A>	27 - 28 - 29 - 31	27 - 28 - 30 - 31	27 - 28 - 30 - 31	28 - 29 - 30 - 32	
Insulation material			PS				
Air filter			PP honeycomb				
Protection device			Fuse				
Refrigerant control device			LEV				
Connectable outdoor unit			R410A, R407C, R22 CITY MULTI				
Diameter of refrigerant pipe	Liquid (R410A) (R22, R407C)	mm (in.)	φ6.35 (φ1/4") Flare	φ6.35 (φ1/4") Flare	φ6.35 (φ1/4") Flare	φ9.52 (φ3/8") Flare	
			φ6.35 (φ1/4") Flare	φ6.35 (φ1/4") Flare	φ9.52 (φ3/8") Flare	φ9.52 (φ3/8") Flare	
	Gas (R410A) (R22, R407C)	mm (in.)	φ12.7 (φ1/2") Flare	φ12.7 (φ1/2") Flare	φ12.7 (φ1/2") Flare	φ15.88 (φ5/8") Flare	
Field drain pipe size		mm (in.)	O.D. φ32 (VP-25)				
Standard attachment	Document		Installation Manual, Instruction Book				
	Accessory						
Remark	Optional parts						
	Decoration panel **1		PLP-6BA	PLP-6BA	PLP-6BA	PLP-6BA	
	Air outlet shutter plate		PAC-SH51SP-E	PAC-SH51SP-E	PAC-SH51SP-E	PAC-SH51SP-E	
	High efficiency filter element **2		PAC-SH59KF-E	PAC-SH59KF-E	PAC-SH59KF-E	PAC-SH59KF-E	
	Multi-function casement		PAC-SH53TM-E	PAC-SH53TM-E	PAC-SH53TM-E	PAC-SH53TM-E	
		**1.PLFY-P-VBM-E should use together with PLP-6BA. **2.PAC-SH53TM-E is necessary to use with filter PAC-SH59KF-E.					
Installation		Details on foundation work, duct work, insulation work, electrical wiring, power source switch, and other items shall be referred to the Installation Manual.					
Note :			* 1 Nominal cooling conditions	* 2 Nominal cooling conditions	* 3 Nominal heating conditions	Unit converter	
Indoor :			27°C DB/19°C WB (81°FDB/66°FWB)	27°C DB/19.5°C WB (81°FDB/67°FWB)	20°C DB (68°FDB)	kcal/h = kW x 860	
Outdoor :			35°C DB (95°FDB)	35°C DB (95°FDB)	7°C DB/6°C WB (45°FDB/43°FWB)	Btu/h = kW x 3,412	
Pipe length :			7.5 m (24-9/16 ft)	5 m (16-3/8 ft)	7.5 m (24-9/16 ft)	cfm = m ³ /min x 35.31	
Level difference :			0 m (0 ft)	0 m (0 ft)	0 m (0 ft)	lb = kg / 0.4536	
* Nominal conditions 1, 3 are subject to JIS B8615-1.						* Above specification data is subject to rounding variation.	
* Due to continuing improvement, above specification may be subject to change without notice.							

1. SPECIFICATIONS

R410A Data G4

Model		PLFY-P80VBM-E	PLFY-P100VBM-E	PLFY-P125VBM-E		
Power source		1-phase 220-240V 50Hz, 1-phase 220V 60Hz				
Cooling capacity (Nominal)	* 1 kW	9.0	11.2	14.0		
	* 1 kcal / h	7,700	9,600	12,000		
	* 1 Btu / h	30,700	38,200	47,800		
	* 2 kcal / h	8,000	10,000	12,500		
	Power input	kW	0.07	0.15	0.16	
	Current input	A	0.51	1.00	1.07	
Heating capacity (Nominal)	* 3 kW	10.0	12.5	16.0		
	* 3 kcal / h	8,600	10,800	13,800		
	* 3 Btu / h	34,100	42,700	54,600		
	Power input	kW	0.06	0.14	0.15	
	Current input	A	0.43	0.94	1.00	
External finish		Galvanized steel sheet				
External dimension H x W x D		mm 258 x 840 x 840	298 x 840 x 840			
		in. 10-3/16" x 33-1/8" x 33-1/8"	11-3/4" x 33-1/8" x 33-1/8"			
Net weight		kg (lb)	23(51)	27(60)	27(60)	
Decoration panel	Model	PLP-6BA		PLP-6BA	PLP-6BA	
	External finish	MUNSELL (6.4Y 8.9/0.4)				
	Dimension	mm	35 x 950 x 950			
	H x W x D	in.	1-3/8" x 37-7/16" x 37-7/16"			
	Net weight	kg (lb)	6(13)			
Heat exchanger		Cross fin (Aluminum fin and copper tube)				
FAN	Type x Quantity		Turbo fan x 1	Turbo fan x 1	Turbo fan x 1	
	External static press.	Pa	0	0	0	
		mmH ₂ O	0	0	0	
	Motor type		DC motor			
	Motor output	kW	0.050	0.120	0.120	
	Driving mechanism		Direct-drive			
	Airflow rate (Low-Mid2- Mid1-High)	m ³ / min	16 - 18 - 20 - 22	21 - 24 - 27 - 29	22 - 25 - 28 - 30	
L / s		267 - 300 - 333 - 367	350 - 400 - 450 - 483	367 - 417 - 467 - 500		
cfm		565 - 636 - 706 - 777	742 - 848 - 953 - 1024	777 - 883 - 989 - 1059		
Noise level (Low-Mid2-Mid1-High) (measured in anechoic room)	dB <A>	30 - 32 - 35 - 37	34 - 37 - 39 - 41	35 - 38 - 41 - 43		
Insulation material		PS				
Air filter		PP honeycomb				
Protection device		Fuse				
Refrigerant control device		LEV				
Connectable outdoor unit		R410A, R407C, R22 CITY MULTI				
Diameter of refrigerant pipe	Liquid (R410A) (R22, R407C)	mm (in.)	φ9.52 (φ3/8") Flare	φ9.52 (φ3/8") Flare	φ9.52 (φ3/8") Flare	
			φ9.52 (φ3/8") Flare	φ9.52 (φ3/8") Flare	φ9.52 (φ3/8") Flare	
	Gas (R410A) (R22, R407C)	mm (in.)	φ15.88 (φ5/8") Flare	φ15.88 (φ5/8") Flare	φ15.88 (φ5/8") Flare	
			φ15.88 (φ5/8") Flare	φ19.05 (φ3/4") Flare	φ19.05 (φ3/4") Flare	
Field drain pipe size	mm (in.)	O.D. φ32 (VP-25)				
Standard attachment	Document Accessory	Installation Manual, Instruction Book				
Remark	Optional parts					
	Decoration panel **1	PLP-6BA	PLP-6BA	PLP-6BA		
	Air outlet shutter plate	PAC-SH51SP-E	PAC-SH51SP-E	PAC-SH51SP-E		
	High efficiency filter element **2	PAC-SH59KF-E	PAC-SH59KF-E	PAC-SH59KF-E		
	Multi-function casement	PAC-SH53TM-E	PAC-SH53TM-E	PAC-SH53TM-E		
Installation		Details on foundation work, duct work, insulation work, electrical wiring, power source switch, and other items shall be referred to the Installation Manual.				
Note :		* 1 Nominal cooling conditions	* 2 Nominal cooling conditions	* 3 Nominal heating conditions	Unit converter	
Indoor :		27°C DB/19°C WB (81°FDB/66°FWB)	27°C DB/19.5°C WB (81°FDB/67°FWB)	20°C DB (68°FDB)	kcal/h = kW x 860	
Outdoor :		35°C DB (95°FDB)	35°C DB (95°FDB)	7°C DB/6°CWB (45°FDB/43°FWB)	Btu/h = kW x 3,412	
Pipe length :		7.5 m (24-9/16 ft)	5 m (16-3/8 ft)	7.5 m (24-9/16 ft)	cfm = m ³ /min x 35.31	
Level difference :		0 m (0 ft)	0 m (0 ft)	0 m (0 ft)	lb = kg / 0.4536	
* Nominal conditions 1, 3 are subject to JIS B8615-1.					*Above specification data is subject to rounding variation.	
* Due to continuing improvement, above specification may be subject to change without notice.						

PLFY-P20,25,32,40VCM-E

Drw. : IU-RG01-N654
Unit : mm

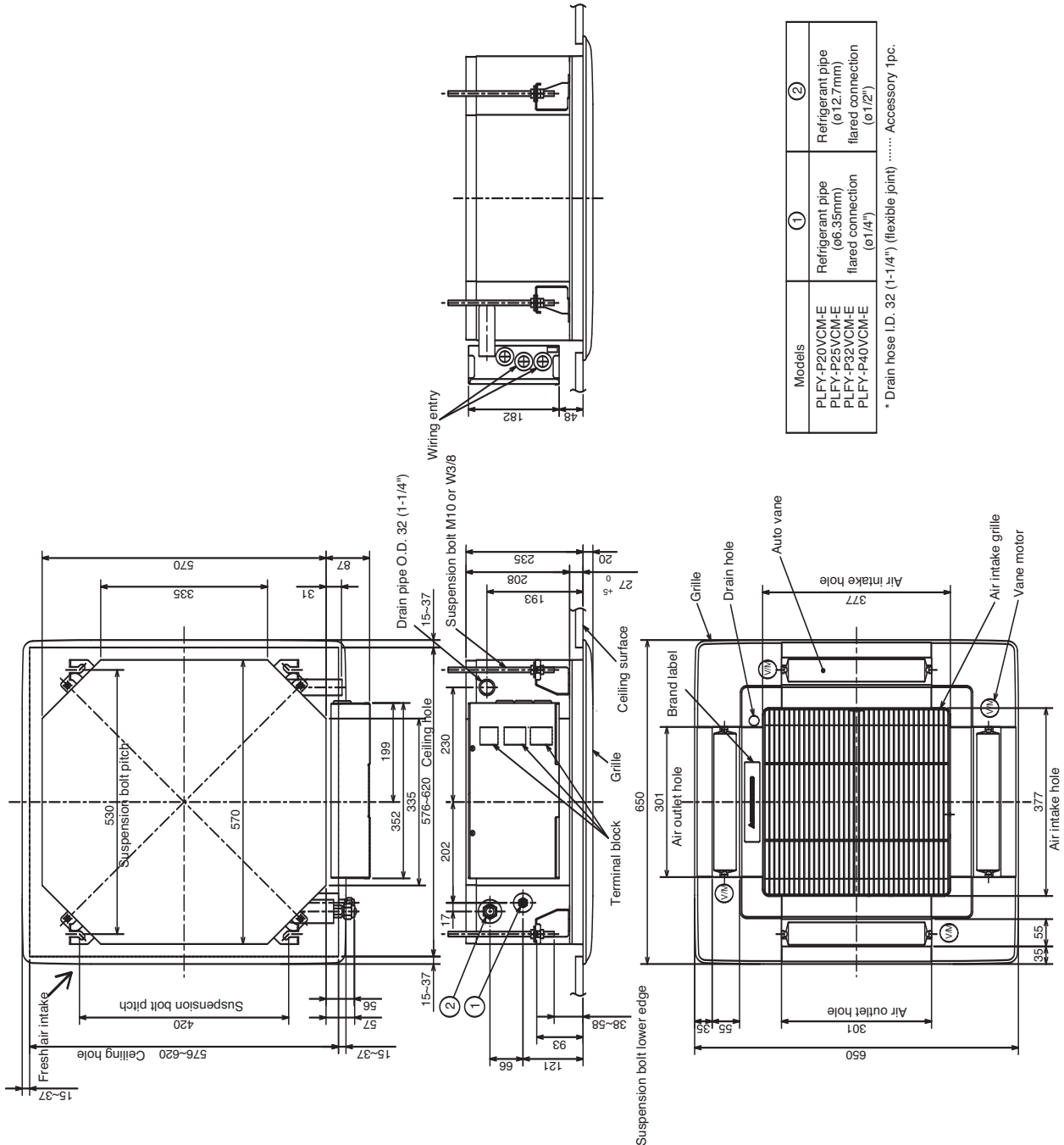

Models	①	②
PLFY-P20VCM-E	Refrigerant pipe (ø6.35mm) flared connection (ø1/4")	Refrigerant pipe (ø12.7mm) flared connection (ø1/2")
PLFY-P25VCM-E		
PLFY-P32VCM-E		
PLFY-P40VCM-E		

* Drain hose I.D. 32 (1-1/4") (flexible joint) Accessory 1pc.

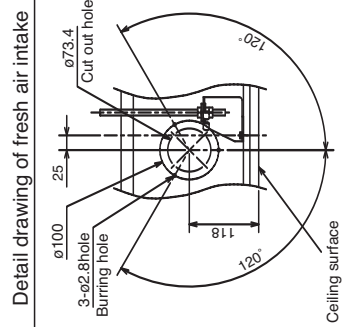

*The fresh air intake hole flange should be supplied in the field.

PLFY-P32,40,50,63,80,100,125VBM-E

Unit : mm

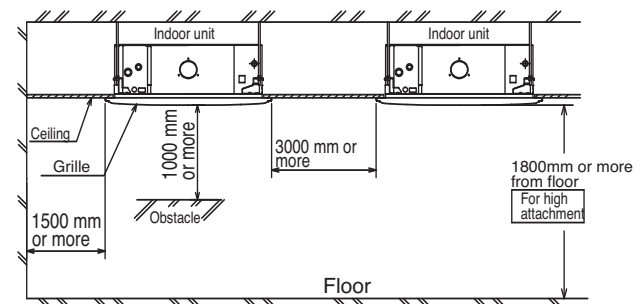
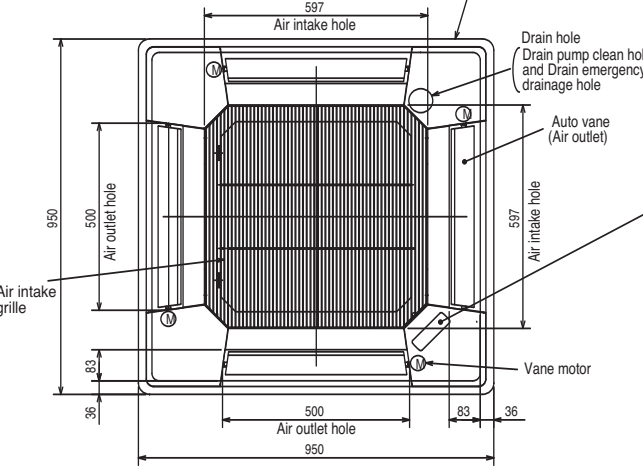
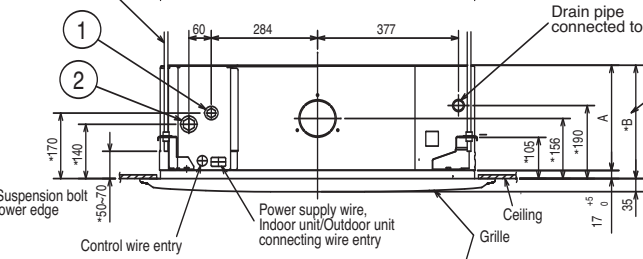
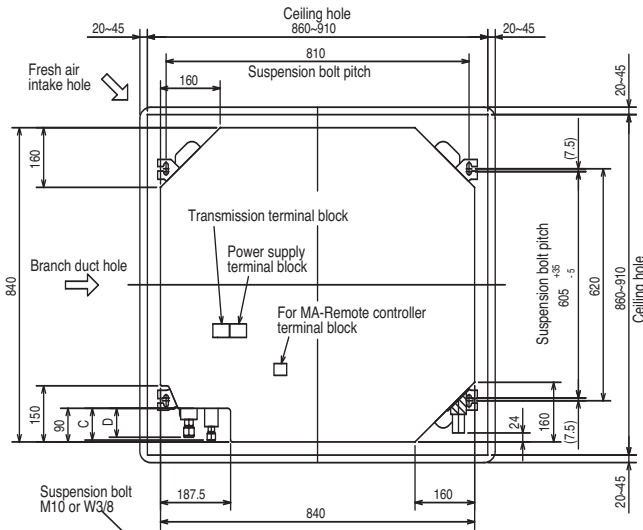

Detail connecting of Branch duct(Both aspects)

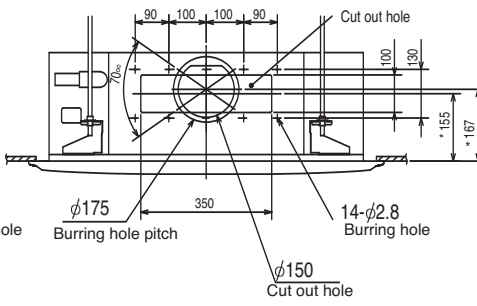

Detail drawing of fresh air intake hole

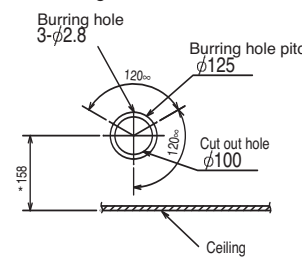

Drain pipe connected to VP-25 (Connected the attached flexible pipe or socket.)

Keep approximately 10 to 15 mm space between unit ceiling and ceiling slab.

In case of standard grille : PLP-6BA



In case of Auto-Grille : PLP-6BAJ

In case of wireless remote controller : PLP-6BALM

Emergency operation switch<Cooling> and Emergency Up/Down switch<Up>

Emergency operation switch<Heating>and Emergency Up/Down switch<Down>

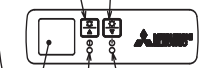

Receiver DEFROST/STAND BY lamp Operation lamp

Auto-Grille Air intake grille Up/down distance

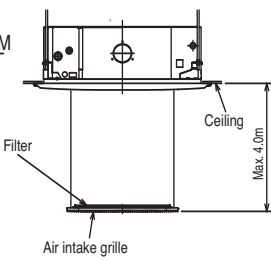

- Note 1. Please choose the Grille from a standard grille, Auto-Grille.
 2. As for drain pipe, please use VP-25(O.D. φ32 PVC TUBE).
 Drain pump inclusion.
 Raise is max 850mm from the ceiling.
 3. As for suspension bolt, please use M10 or W3/8. (Procured at local site)
 4. Electrical box may be removed for the service purpose.
 Make sure to slack the electrical wire little bit for control/power wires connection.
 5. The height of the indoor unit is able to be adjusted with the grille attached.
 6. For the installation of the optional high efficiency filter or optional multi-functional casement.
 1) Requires E or more space between transom and ceiling for the installation.
 2) Add 135 mm to the dimensions * marked on the figure.
 3) The optional high efficiency filter becomes optional multi-functional casement and concomitant use.
 7. When installing the branch ducts, be sure to insulate adequately.
 Otherwise condensation and dripping may occur.
 (It becomes the cause of dew drops/Wear dew.)
 8. As for necessary installation/service space, please refer to the under at figure.

Accessory ... Drain socket (I.D. 32)
 Flare nut 3/8F(For P50)
 Flare nut 5/8F(For P50)
 Flare nut 3/4F(For P100/P125)

Models	1	2	A	B	C	D	E
PLFY-P32,40VBM-E	Refrigerant pipe--φ 6.35 Flared connection--1/4F	Refrigerant pipe --φ12.7 Flared connection--1/2F			80	74	
PLFY-P50VBM-E	Refrigerant pipe φ6.35 /φ9.52 Flared connection 1/4F / 3/8F (compatible)	Refrigerant pipe φ12.7 /φ15.88 Flared connection 1/2F / 5/8F (compatible)	241	258	87	78	400
PLFY-P63,80VBM-E	Refrigerant pipe--3/8F Flared connection--φ9.52	Refrigerant pipe--φ15.88 Flared connection--5/8F				77	
PLFY-P100,125VBM-E		Refrigerant pipe φ15.88 / φ19.05 Flared connection 5/8F / 3/4F (compatible)	281	298	85	81	440

PLFY-P20,25,32,40VCM-E

Draw. : IU-RG79-N625

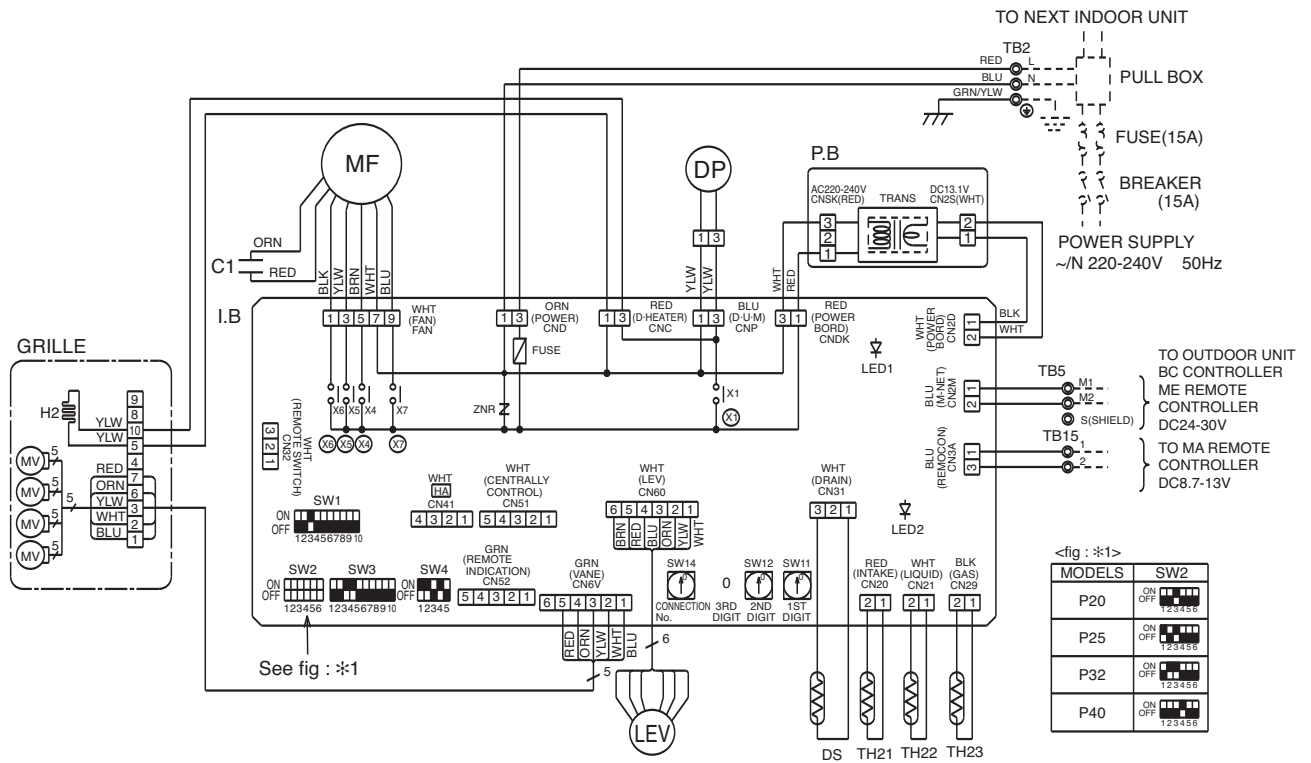

[LEGEND]

SYMBOL	NAME	SYMBOL	NAME
I.B	INDOOR CONTROLLER BOARD	C1	CAPACITOR (FAN MOTOR)
CN32	CONNECTOR	DP	DRAIN WATER LIFTING-UP MACHINE
CN41	REMOTE SWITCH	DS	DRAIN SENSOR
CN51	HA TERMINAL-A	H2	DEW PREVENTION HEATER
CN52	CENTRALLY CONTROL	LEV	LINEAR EXPANSION VALVE
CN52	REMOTE INDICATION	MF	FAN MOTOR (WITH THERMAL FUSE)
FUSE	FUSE (6.3A/250V)	MV	VANE MOTOR
SW1	SWITCH	TB2	POWER SUPPLY
SW2	MODE SELECTION	TB5	TRANSMISSION
SW3	CAPACITY CODE	TB15	MA REMOTE CONTROLLER
SW4	MODE SELECTION	TH21	ROOM TEMP. DETECTION
SW11	MODEL SELECTION	TH22	PIPE TEMP. DETECTION/LIQUID
SW12	ADDRESS SETTING 1ST DIGIT	TH23	PIPE TEMP. DETECTION/GAS
SW14	ADDRESS SETTING 2ND DIGIT	P.B	INDOOR POWER BOARD
X1	AUX. RELAY		
X4	DRAIN PUMP/DEW PREVENTION HEATER		
X5	FAN MOTOR (LL)		
X6	FAN MOTOR (Lo)		
X7	FAN MOTOR (Hi)		
ZNR	VARISTOR		

Notes:

- At servicing for outdoor unit, always follow the wiring diagram of outdoor unit.
- In case of using MA Remote controller, please connect to TB15. (Remote controller wire is non-polar.)
- In case of using M-NET, please connect to TB5. (Transmission line is non-polar.)
- Symbol[S] of TB5 is the shield wire connection.
- Symbols used in wiring diagram above are, :terminal block, :connector.
- The setting of the SW2 dip switches differs in the capacity for the detail, refer to the fig : *1.

LED on indoor board for service

Mark	Meaning	Function
LED1	Main power supply	Main power supply (Indoor unit: 220-240V) power on lamp is lit
LED2	Power supply for MA Remote controller	Power supply for MA Remote controller on lamp is lit

PLFY-P32,40,50,63,80,100,125VBM-E

[LEGEND]

SYMBOL	NAME	SYMBOL	NAME	SYMBOL	NAME
I. B	INDOOR CONTROLLER BOARD	TB2	TERMINAL BLOCK	POWER SUPPLY	OPTION PART
CN27	CONNECTOR	TB5	TERMINAL BLOCK	TRANSMISSION	W.B PCB FOR WIRELESS REMOTE CONTROLLER
CN32	CONNECTOR	TB15	TERMINAL BLOCK	MA-REMOTE CONTROLLER	BZ BUZZER
CN51	CONNECTOR	TH21	THERMISTOR	ROOM TEMP. DETECTION	LED1 LED (OPERATION INDICATION : GREEN)
CN52	CONNECTOR	TH22	THERMISTOR	PIPE TEMP. DETECTION / LIQUID	LED2 LED (PREPARATION FOR HEATING : ORANGE)
DSA	SURGE ABSORBER	TH23	THERMISTOR	PIPE TEMP. DETECTION / GAS	RU RECEIVING UNIT
FUSE	FUSE (T6.3AL250V)			(0°C / 15kΩ, 25°C / 5.4kΩ)	SW1 EMERGENCY OPERATION (HEAT / DOWN)
LED1	POWER SUPPLY (I. B)			(0°C / 15kΩ, 25°C / 5.4kΩ)	SW2 EMERGENCY OPERATION (COOL / UP)
LED2	POWER SUPPLY (I. B)	A. B	ADDRESS BOARD		
SW2	SWITCH	SWA	SWITCH	CEILING HEIGHT SELECTOR	
SW3	SWITCH	SWB	SWITCH	DISCHARGE OUTLET NUMBER SELECTOR	
SW4	SWITCH	SWC	SWITCH	OPTION SELECTOR	
SWE	SWITCH	SW1	SWITCH	MODE SELECTION	
X1	AUX. RELAY	SW11	SWITCH	ADDRESS SETTING 1ST DIGIT	
ZNR01,02	VARIATOR	SW12	SWITCH	ADDRESS SETTING 2ND DIGIT	
		SW14	SWITCH	CONNECTION NO.	
DP	DRAIN-UP MACHINE				
FS	DRAIN FLOAT SWITCH				
LEV	LINEAR EXPANSION VALVE				
MF	FAN MOTOR				
MV	VANE MOTOR				

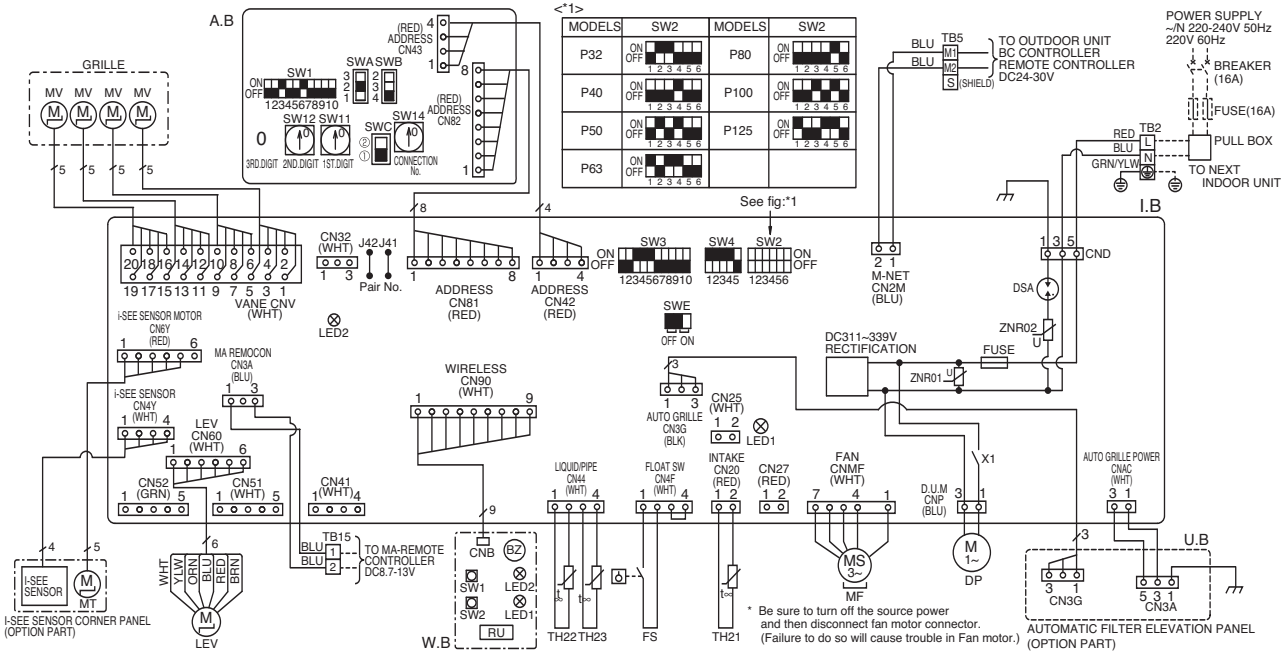

NOTES:

1. At servicing for outdoor unit, always follow the wiring diagram of outdoor unit.
2. In case of using MA-Remote controller, please connect to TB15.
(Remote controller wire is non-polar.)
3. In case of using M-NET, please connect to TB5. (Transmission line is non-polar.)
4. Symbol [S] of TB5 is the shield wire connection.
5. Symbols used in wiring diagram above are, : terminal block, : connector.
6. The setting of the SW2 dip switches differs in the capacity. For the detail, refer to fig<*1>.

LED on indoor board for service

Mark	Meaning	Function
LED1	Main power supply	Main Power supply (Indoor unit:220-240V) power on – lamp is lit
LED2	Power supply for MA-Remote controller	Power supply for MA-Remote controller on – lamp is lit

4. SOUND LEVELS

4-1. Sound levels

PLFY-P-VCM-E, VBM-E

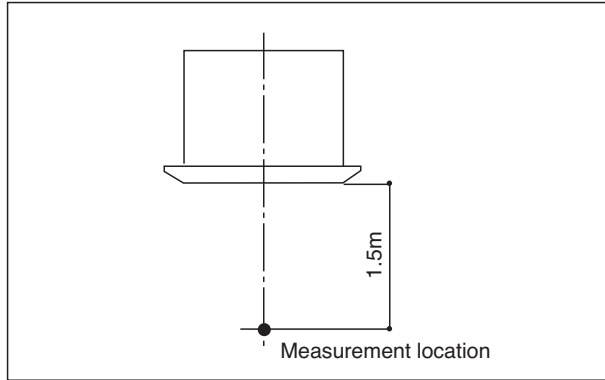

* Measured in anechoic room.

Sound level at anechoic room : Low-Mid-High

	Sound level dB (A)
PLFY-P20VCM-E	28-31-35
PLFY-P25VCM-E	28-31-37
PLFY-P32VCM-E	29-33-38
PLFY-P40VCM-E	30-34-39

Sound level at anechoic room : Low-Mid2-Mid1-High

	Sound level dB (A)
PLFY-P32VBM-E	27-28-29-31
PLFY-P40VBM-E	27-28-30-31
PLFY-P50VBM-E	27-28-30-31
PLFY-P63VBM-E	28-29-30-32
PLFY-P80VBM-E	30-32-35-37
PLFY-P100VBM-E	34-37-39-41
PLFY-P125VBM-E	35-38-41-43

4-2. NC curves

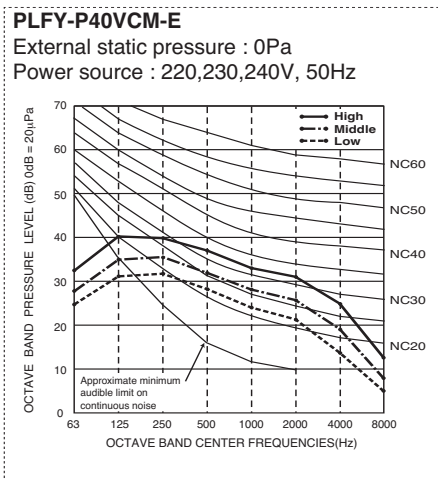
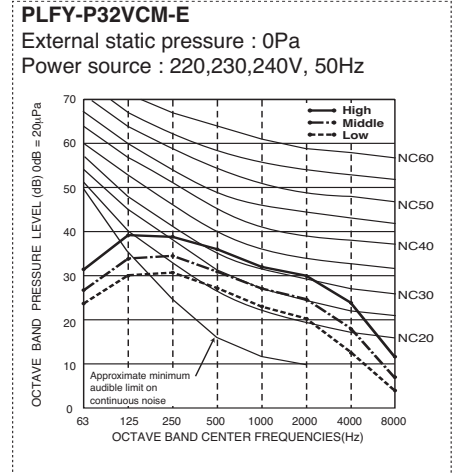
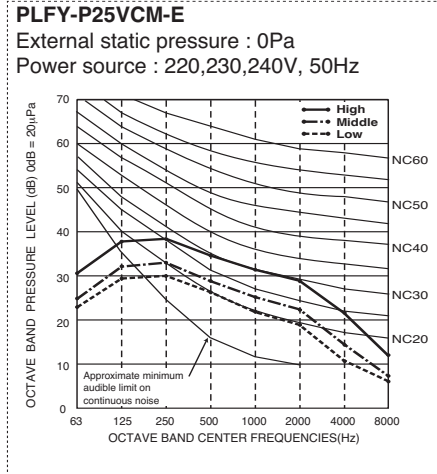
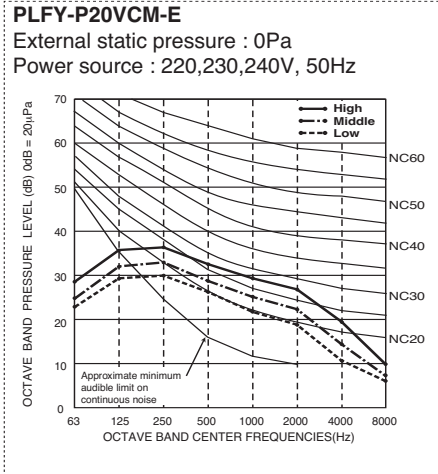

4-2. NC curves

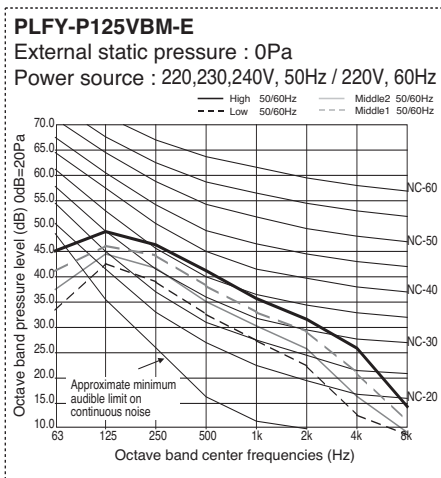
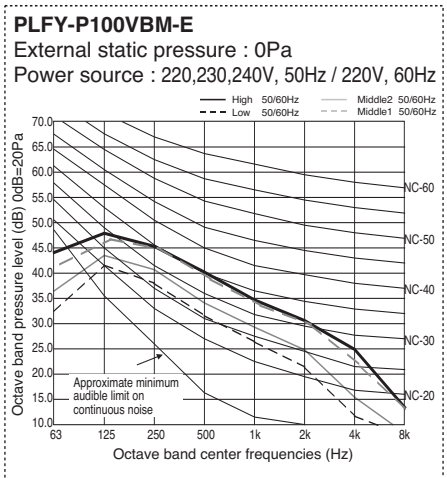
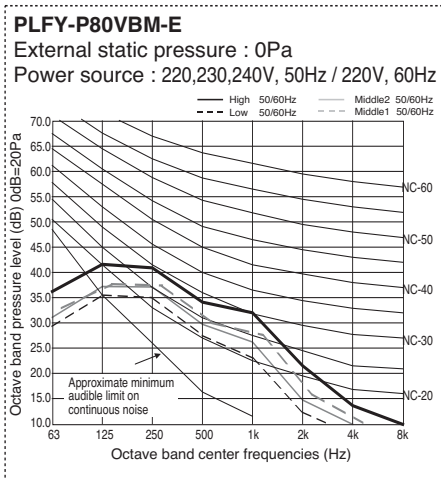
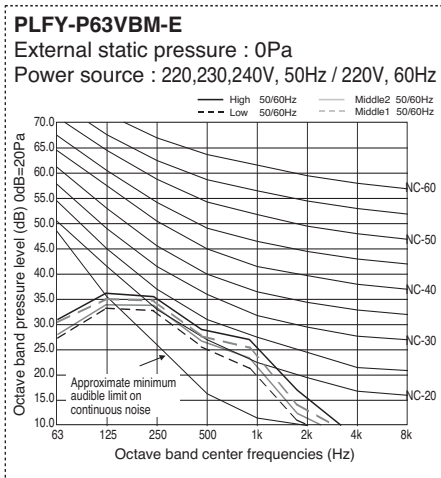
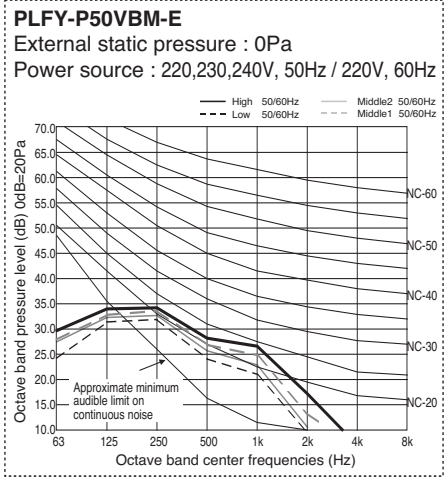
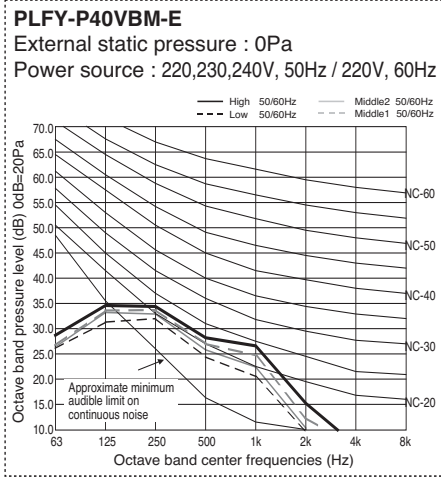
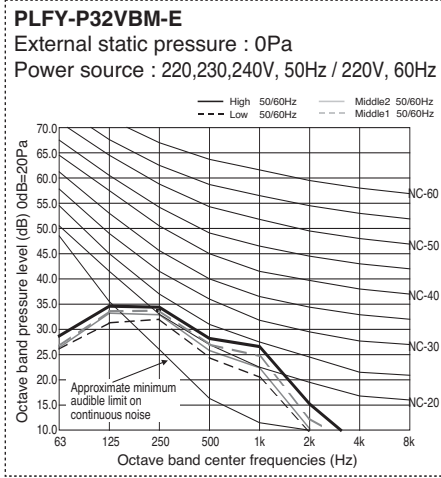

5-1. Temperature distributions

PLFY-P-VCM-E

<Cooling mode>

Flow angle 30°

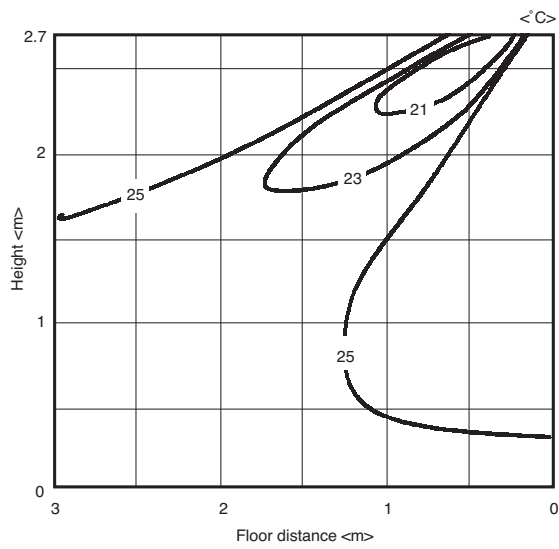

<Heating mode>

Flow angle 70°

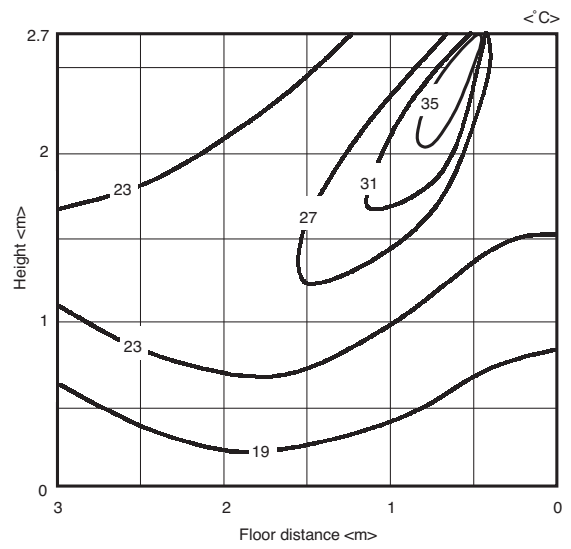

Note : These figures show typical temperature distributions in the conditions above. In the actual installation, they may differ from these figures under the influence of air temperature conditions, ceiling height, cooling/heating load, obstacles, etc.

5-1. Temperature distributions

PLFY-P-VBM-E

• PLY-P80VBM-E
 <Cooling mode> Standard
 Flow angle : 30° 4-way flow
 ceiling height : 2.7 m

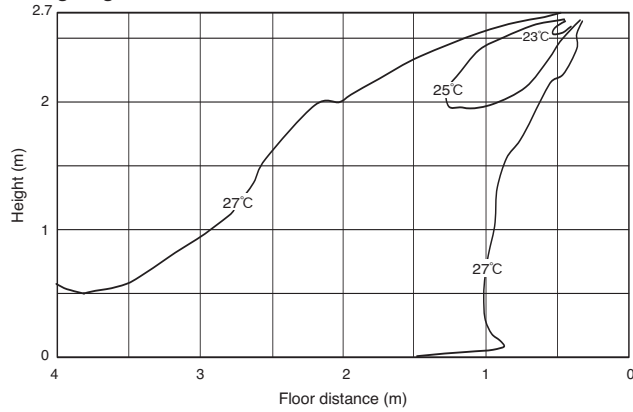

• PLY-P80VBM-E
 <Heating mode> Standard
 Flow angle : 60° 4-way flow
 ceiling height : 2.7 m

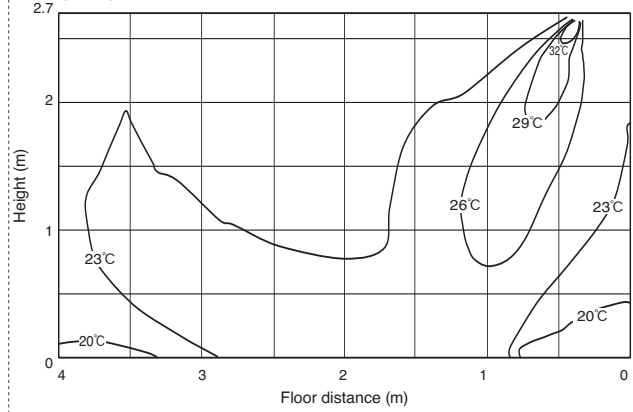

• PLY-P125VBM-E
 <Cooling mode> Standard
 Flow angle : 30° 4-way flow
 ceiling height : 3.2 m

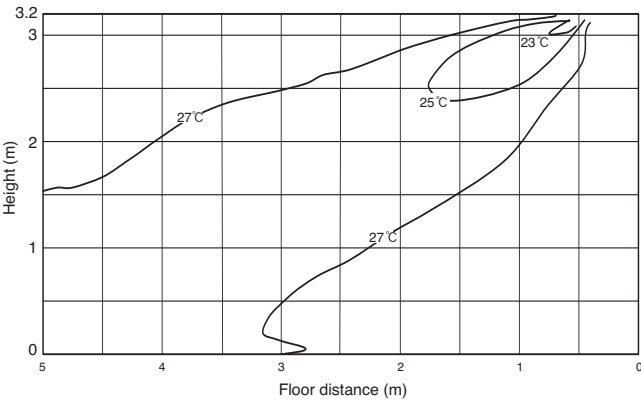

• PLY-P125VBM-E
 <Heating mode> Standard
 Flow angle : 60° 4-way flow
 ceiling height : 3.2 m

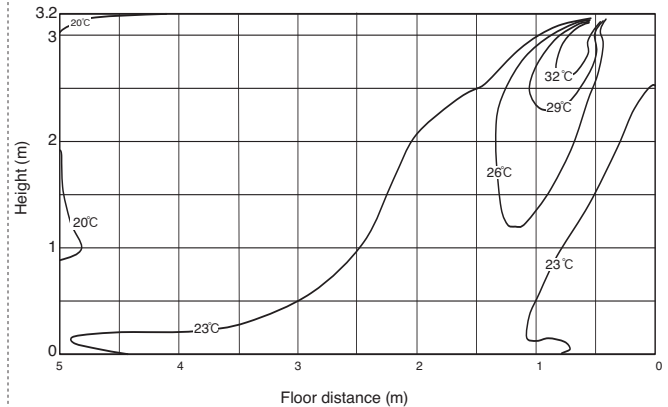

Note : These figures show typical temperature distributions in the conditions above. In the actual installation, they may differ from these figures under the influence of air temperature conditions, ceiling height, cooling/heating load, obstacles, etc.

5-2. Airflow distributions

PLFY-P-VCM-E

<Fan mode>
Flow angle 70°

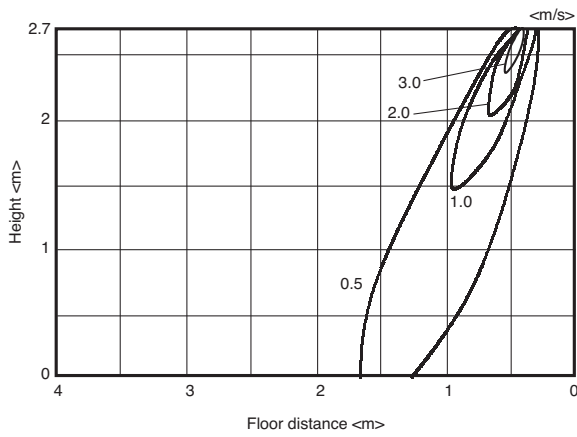

<Fan mode>
Flow angle 30°

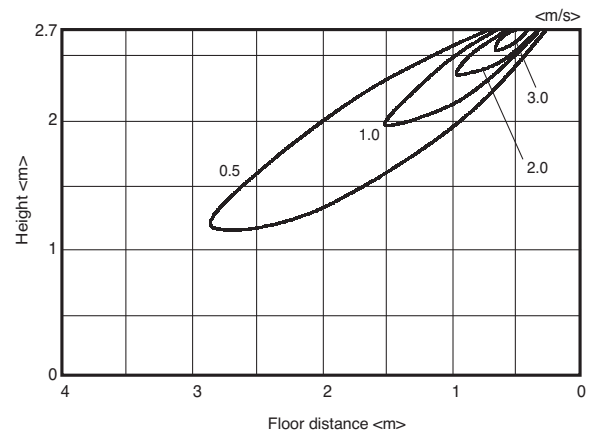

PLFY-P80VBM-E

<Heating mode>
Flow angle 60°

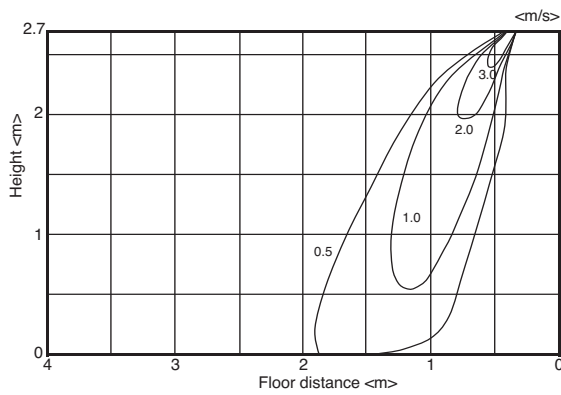

<Cooling mode>
Flow angle 30°

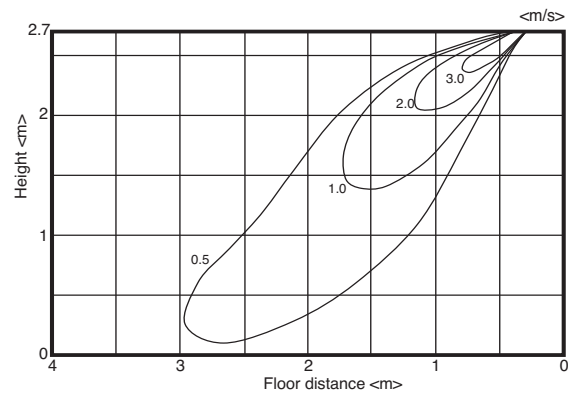

PLFY-P125VBM-E

<Heating mode>
Flow angle 60°

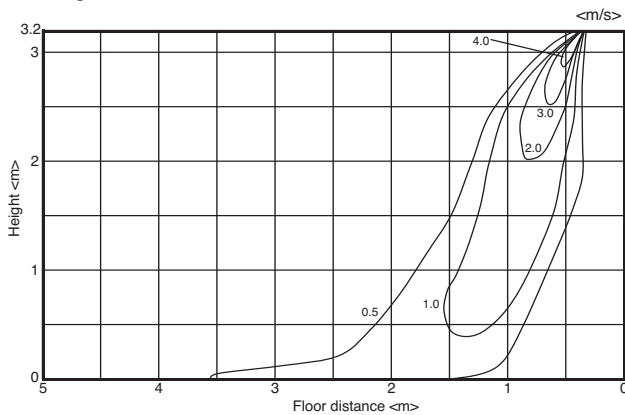

<Cooling mode>
Flow angle 30°

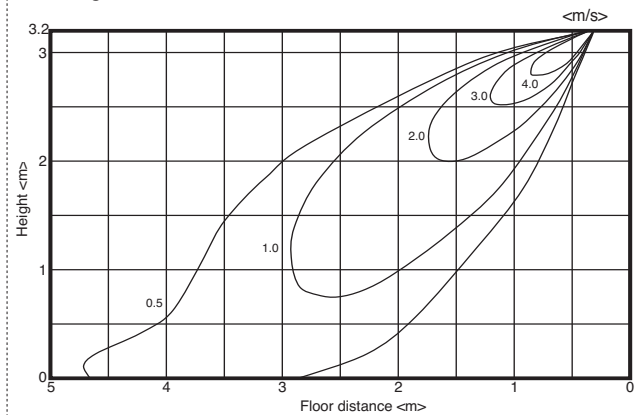

Note : These figures show typical airflow distributions in the conditions above. In the actual installation, they may differ from these figures under the influence of air temperature conditions, ceiling height, cooling/heating load, obstacles, etc.

Optional parts line up for the Indoor unit

	Air outlet shutter plate	Multi-function casement	High efficiency filter element
PLFY-P-VBM-E	PAC-SH51SP-E	PAC-SH53TM-E	PAC-SH59KF-E

PLFY-P-VBM-E

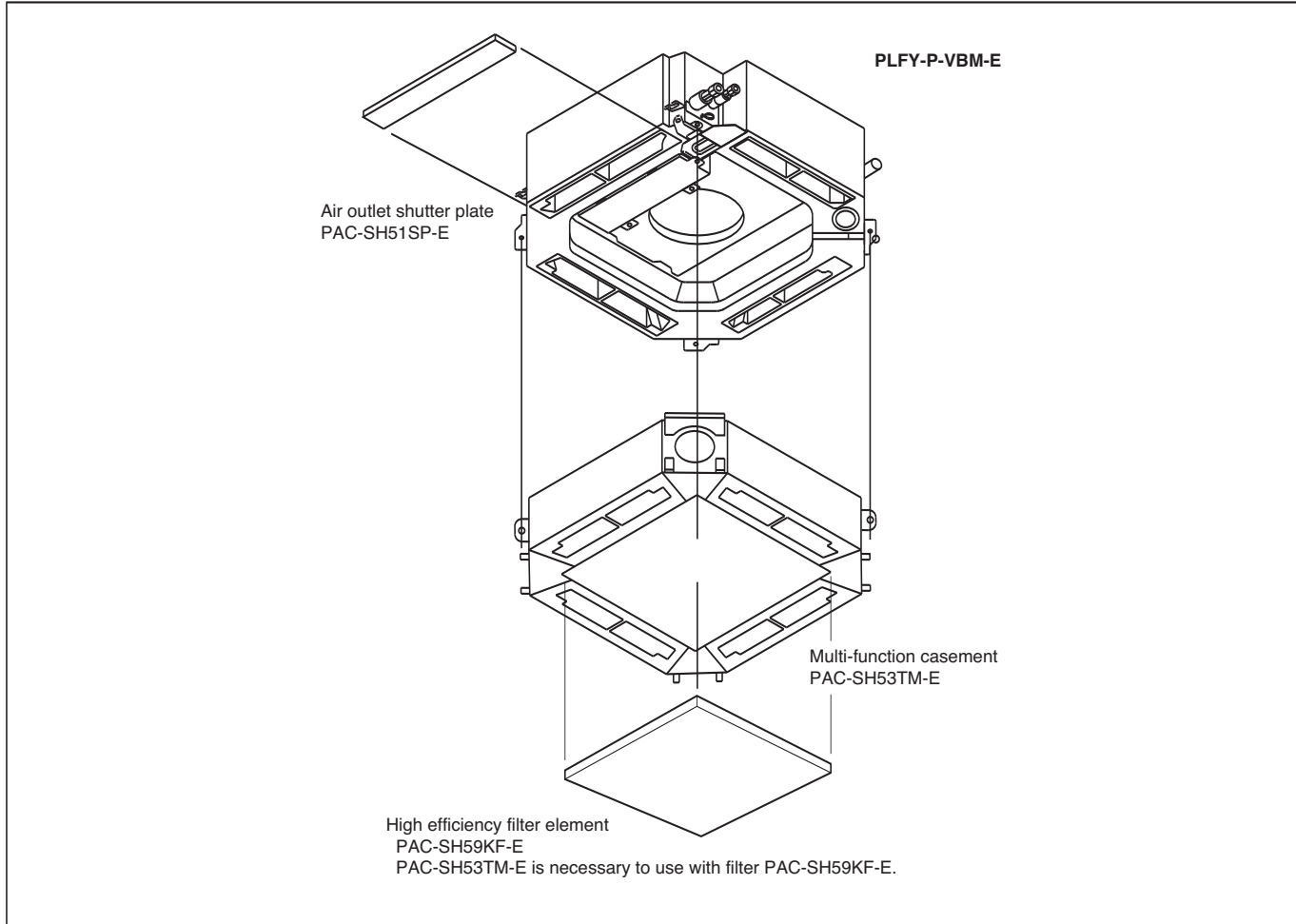

Air outlet shutter plate PAC-SH51SP-E for PLFY-P-VBM-E

Using the air outlet shutter plate to block the air outlet to modify the air-way from 4 to 3 or 2.
 With 1 PAC-SH51SP-E, 4 air-ways can be changed to 3;
 With 2 PAC-SH51SP-E, 4 air-ways can be changed to 2;
 Changing to 1 way is not allowed.
 Material: Foamed polyethylene + foamed urethane, color: black.

Item	① Shutter plate	② Insulator	
Quantity	2	1	
Shape			

Detailed installation information should be referred to its Installation Manual (BH79G726H01)

Optional parts line up for the Indoor unit

	Air outlet shutter plate	Multi-function casement	High efficiency filter element
PLFY-P-VBM-E	PAC-SH51SP-E	PAC-SH53TM-E	PAC-SH59KF-E

High efficiency filter element PAC-SH59KF-E for PLFY-P-VBM-E



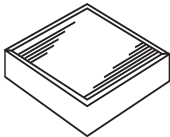

Life span: 2,500 hr (Dust concentration 0.15mg/m³); Colorimetric method 65% (JIS 11 class)); No re-production.
 * The actual dust situation affects the filter life span, which should be considered at the applying site.
 Material: Electrostatic polyolefin fiber
 High efficiency filter element PAC-SH59KF-E should be used together with the Multi-function casement PAC-SH53TM-E. When using PAC-SH59KF-E, switching on SWC of the Indoor unit address board is needed. Details are referred to its Installation Manual.

Quantity	1	
Shape		

Detailed installation information should be referred to its Installation Manual (BH79G727H01)

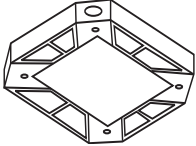
Multi-function casement PAC-SH53TM-E for PLFY-P-VBM-E

Multi-function casement is used for High efficiency filter element and/or fresh air intake from outdoor.
 It should be used with High efficiency filter element PAC-SH59KF-E (Colorimetric method 65%).
 Fresh air intake on the Multi-function casement is possible from any 2 or less corners among the 4 ones.
 But duct and flange on the casement should be prepare locally.

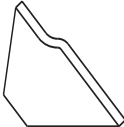
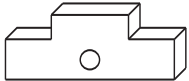
Item	① Multi-functional casement	② Screw with washer (black)	③ Screw
Quantity	1	4	8
Shape		M5X0.8X25 	M5X0.8X12 
Item	④ Decorative panel securing bracket	⑤ Insulator A for Decorative panel	⑥ Insulator B for Decorative panel
Quantity	4	1	1
Shape	With insulator 		

Detailed installation information should be referred to its Installation Manual (RG79Y264H01)

■ Optional parts line up for the Indoor unit

	i-see Sensor corner panel	Automatic filter elevation panel	Wireless signal receiver
PLFY-P-VBM-E	PAC-SA1ME-E	PLP-6BAJ	PAR-SA9FA-E



■ i-see sensor corner panel PAC-SA1ME-E for PLFY-P-VBM-E

i-see sensor provides comfortable space as it detects the floor temperature to prevent spotty temperature. And that enables the unit to save energy.

Attention

Make sure that there are no gaps between the unit and the grille, and the grille and ceiling.

* It way cause dew dripping.

Item	① i-see sensor corner panel	② Plastic fastener
Quantity	1	2
Shape		

Detailed installation information should be referred to its Installation Manual (RG79V563H01)

■ Automatic filter elevation panel PLP-6BAJ for PLFY-P-VBM-E

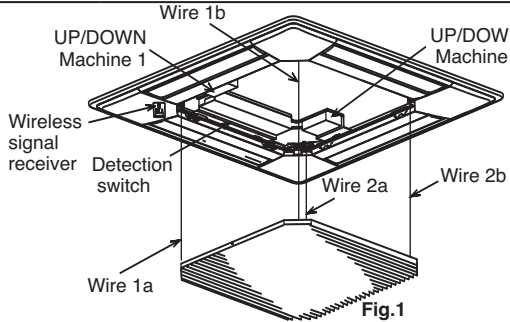
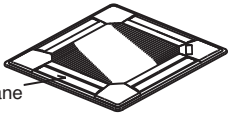
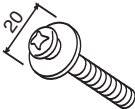
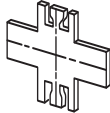

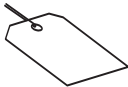





Fig.1

- Air intake grille can be lifted and lowered automatically by wired remote controller (MA type : PAR-21MAA) or wireless remote controller (Item ⑨).
- Lowering the air intake grille allows you to clean the filter easily.
- You can set up eight different stages of lowering distance for the air intake grille according to the set up location if desired. (Maximum : 4m)

Item	① Decorative panel	② Screw with washer	③ Installation gauge	④ Plastic fastener
Quantity	1	4	1	3
Shape			 (Used split into four pieces)	
Item	⑤ Tag	⑥ Screw	⑦ Screw	⑧ Screw
Quantity	1	4	1	3
Shape		 Only three are used		
Item	⑨ Wireless remote controller			
Quantity	1			
Shape				

Detailed installation information should be referred to its Installation Manual (RG79D167K01)

■ Wireless signal receiver PAR-SA9FA-E for PLFY-P-VBM-E

Wireless signal receiver PAR-SA9FA-E is necessary for using wireless remote controller. PAR-SA9FA-E is a corner panel with the signal receiver for wireless remote controller.

Item	① Wireless signal receiver
Quantity	1
Shape	

Detailed installation information should be referred to its Installation Manual (RG79V531H01)